



Care and Use Manual Reverse Osmosis Units

Information Provided for the Proper Set-Up, Installation and Start-Up of the following Filtration Systems

- **Three Stage Undercounter Reverse Osmosis Units:**
RU300C18, RU300C18 w/UV
- **Four Stage Undercounter Reverse Osmosis Units:**
RU400T35, RU400T35 w/UV
- **Five Stage Undercounter Reverse Osmosis Series:**
Heavy Particulate w/ UV and/or Booster Pump Options



ALL PRODUCT PROUDLY MANUFACTURED AND ASSEMBLED IN THE USA

To the Installer: Please Read and Leave this Owner's Manual with the Unit or the Consumer

To the Consumer: Retain this Care & Use Manual for Product Registration and Future Reference



Installation of the Reverse Osmosis System

You may need the following for proper installation:

- Drill and drill bits
- Straight and Phillips Screwdriver
- Adjustable Wrench
- Pliers
- Teflon tape
- Work Gloves
- Safety Glasses
- Knife or scissors

* Additional tools will be required for installation on sinks without a pre-drilled faucet location.

WARNING:

Verify that all components are included with the unit and were not lost, misplaced, or damaged in shipping or handling.

CAUTION:

Do not attempt to install this system using defective or damaged components. Check and inspect, inlet and outlet fittings and any other connections on this system that might have been damaged during shipping and handling.

Summary Procedures for Proper Installation of these Reverse Osmosis Systems

- **Dispenser/Faucet Installation and Mounting**
- **Inlet Water Connection**
- **Placement of the System and Storage Tank**
- **System Interconnection, Tank and Drain Connections**
- **System Start-Up and Operation**



Dispenser/Faucet Installation

Preparing a Location for the Dispenser/Faucet
Professional Installation is Strongly Recommended

Step 1: Select a standard sink location to mount the faucet.

It is recommended that the faucet be placed in the extra hole provided on most sinks usually used for the sprayer or soap dispenser. If this is not possible, an alternative location will be required:

- Option A:** Another option is to drill a new hole into the sink rim itself, if space allows.
- Option B:** On the countertop next to the sink. Position to allow the faucet spout to drain into the sink. This requires a 2" clearance around the faucet--both above and under the countertop.

Step 2: Prepare to drill the hole using the dispenser as your template.

- Sinks can be made of, but not limited to, stainless steel, copper, porcelain/steel, enamel/cast iron, man-made surfaces, and/or materials known or unknown at this time.
- Countertops can be made of, but not limited to, or be a combination of, natural stone, enamel, porcelain, concrete, wood, metals and/or man-made materials known or unknown at this time.

CAUTION: Please consult with the sink or countertop manufacturer, fabricator, or installer for proper drilling techniques and methods.

EXTREME CARE MUST BE TAKEN IN DRILLING THE HOLE FOR ANY SURFACE. THE SURFACE MATERIALS OF SINKS AND COUNTERTOPS CAN CHIP OR CRACK. THE MANUFACTURER ASSUMES NO RESPONSIBILITY FOR ANY DAMAGE RESULTING FROM THIS INSTALLATION.

WARNING: USE SAFETY GLASSES OR OTHER EYE PROTECTION WHEN GRINDING OR DRILLING TO PREVENT POSSIBLE EYE INJURY DUE TO FLYING PARTICLES.

Go to: Mounting the Faucet (with or without Air Gap).

Q:	I do not want to drill any extra holes or use a separate dispenser/faucet - what can I do?
A:	Nothing. Reverse osmosis systems are limited to a separate dispenser. These systems manufacture a limited amount of water and therefore the connection to the cold side of your sink faucet is an unavailable option. In addition, the water produced by a reverse osmosis system is aggressive and would have adverse effects on any other metals (ie: brass, copper) other than stainless steel. Note: Drinking water filtration systems are pass through systems and will allow this option. There will be a diminishment in your flow rate to the cold side of the faucet and to get filtered water you must be sure you have the faucet to the cold side only. Not an option for reverse osmosis systems.
Q:	I would like to use another dispenser/faucet?
A:	Based on many styles and finishes, a consumer may have another dispenser they would like to use. No problem, all these items have universal or industry standard fittings, or if not, can be easily adapted to fit. Note: Be aware - an air gap may be code and required with another dispenser. EWS, Inc. provides dispensers with air gap adaptors. You may be able to upgrade to an all white faucet, or satin nickel with black handle and tip, at a small additional charge. Inquire with your local EWS, Inc. distributor or visit us on the web.
Q:	Can we connect the filtered water up to other devices?
A:	Yes, simply connect by a "T" connection, the filtered water line to any instant hots, chillers, ice-makers, refrigerators, etc. Be mindful of too many (3 or more) connections or see our whole home appliances to filter the whole home. Reverse osmosis may have warranty or restrictions with other devices, consult with mfg.



Mounting the Dispenser/Faucet - with Air Gap Adaptor

Once the location for the Dispenser/Faucet has been prepared follow the remaining step by step instructions to mount and secure

Step 1: Locate faucet parts bag inside the parts box.

Parts Included: faucet body with handle, air gap, faucet spout with tip, decorative washer, black rubber washer, white beveled washer, lock washer, hex nut, 1/4" tube insert sleeve, 1/4" plastic compression ferrule, 1/4" compression nut

Optional Part: flat white washer (for use under decorative washer depending on hole/application)

Above the Surface

Step 2:

Place air gap to bottom of faucet body (optional: place flat white washer under air gap)

Step 3:

Place black rubber washer below air gap (or below optional flat white washer)

Step 4:

Place faucet stem through hole and center

Below the Surface

Step 5:

Insert white beveled washer, bevel side up to fit snugly into a pre-drilled hole or flat side up depending on the application

Step 6:

Place lock washer on

Step 7:

Spin hex nut onto faucet stem and tighten hex nut and washers into place

Step 8:

Insert 1/4" tube insert sleeve into 1/4" filtered water line

Step 9:

Slide 1/4" compression nut (threads up) onto 1/4" filtered line

Step 10:

Slide 1/4" plastic compression ferrule, long side down onto filtered water tube. Ferrule will seat into compression nut

Step 11:

Insert 1/4" filtered water tube into faucet stem

Step 12:

Thread 1/4" compression nut onto faucet stem and tighten

Note: Air gap connections found on page 12; System Interconnection and Drain Connections

CAUTION: Do not overtighten fittings

Note: Spout pulls out from faucet body that's why it swivels. Spout has 2 o-rings at base and is inserted completely into bottom of body to prevent leaking. Handle and tip can also be removed.

**Other faucets check specifications, all dimensions are approximate.

Std. ** Dispenser/Faucet Dimensions:

Height:

from deck to top of dispenser 8"

from deck to tip of dispenser 61/4"

Reach:

from center of dispenser to tip 6"

Hole: minimum required w/gap 11/4"

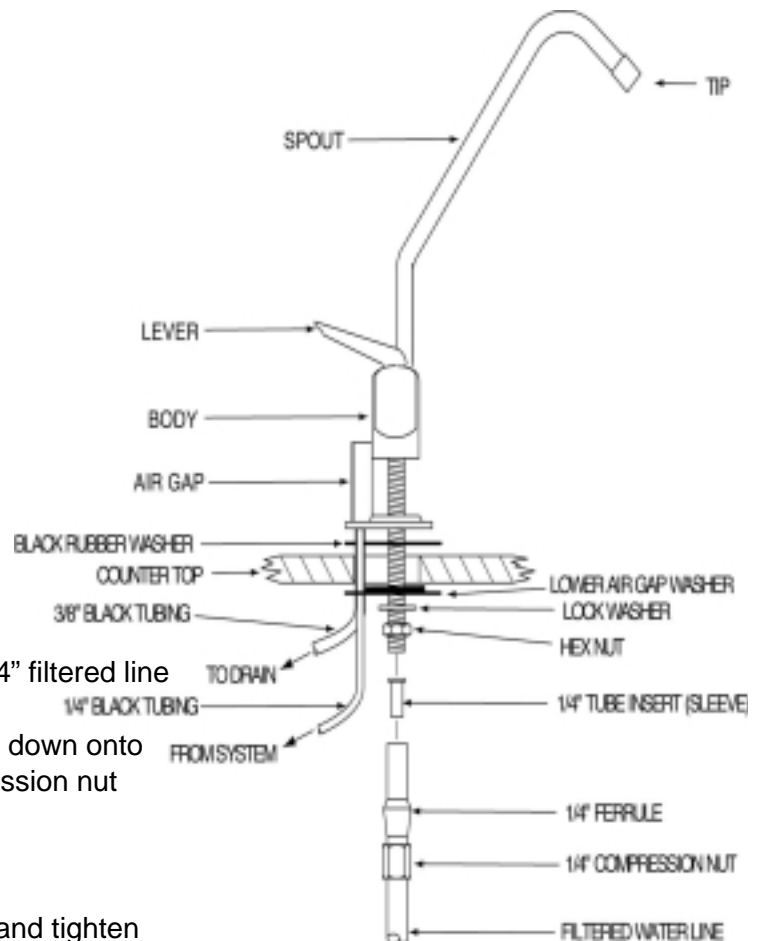

Dispenser/Faucet (with Air Gap) Installation is now Complete. Go To Inlet Water Connection



Mounting the Dispenser/Faucet (without Air Gap)

Once the location for the Dispenser/Faucet has been prepared follow the remaining step by step instructions to mount and secure

Step 1: Locate faucet parts bag inside the parts box.

- Parts Included:** faucet body with handle, air gap, faucet spout with tip, decorative washer, black rubber washer, white beveled washer, lock washer, hex nut, 1/4" tube insert sleeve, 1/4" plastic compression ferrule, 1/4" compression nut
- Optional Part:** flat white washer (for use under decorative washer depending on hole/application)

Above the Surface

Step 2:
Place decorative washer to bottom of faucet body (optional: place flat white washer under decorative washer)

Step 3:
Place black rubber washer below decorative washer (or below optional flat white washer)

Step 4:
Place faucet stem through hole and center

Below the Surface

Step 5:
Insert white beveled washer, bevel side up to fit snugly into a pre-drilled hole or flat side up depending on the application

Step 6:
Place lock washer on

Step 7:
Spin hex nut onto faucet stem and tighten hex nut and washers into place

Step 8:
Insert 1/4" tube insert sleeve into 1/4" filtered water line

Step 9:
Slide 1/4" compression nut (threads up) onto 1/4" filtered line

Step 10:
Slide 1/4" plastic compression ferrule, long side down onto filtered water tube. Ferrule will seat into compression nut

Step 11:
Insert 1/4" filtered water tube into faucet stem

Step 12:
Thread 1/4" compression nut onto faucet stem and tighten

Std.** Dispenser/Faucet Dimensions:

Height:	
from deck to top of dispenser	8"
from deck to tip of dispenser	61/4"
Reach:	
from center of dispenser to tip	6"
Hole: minimum required	1/2"

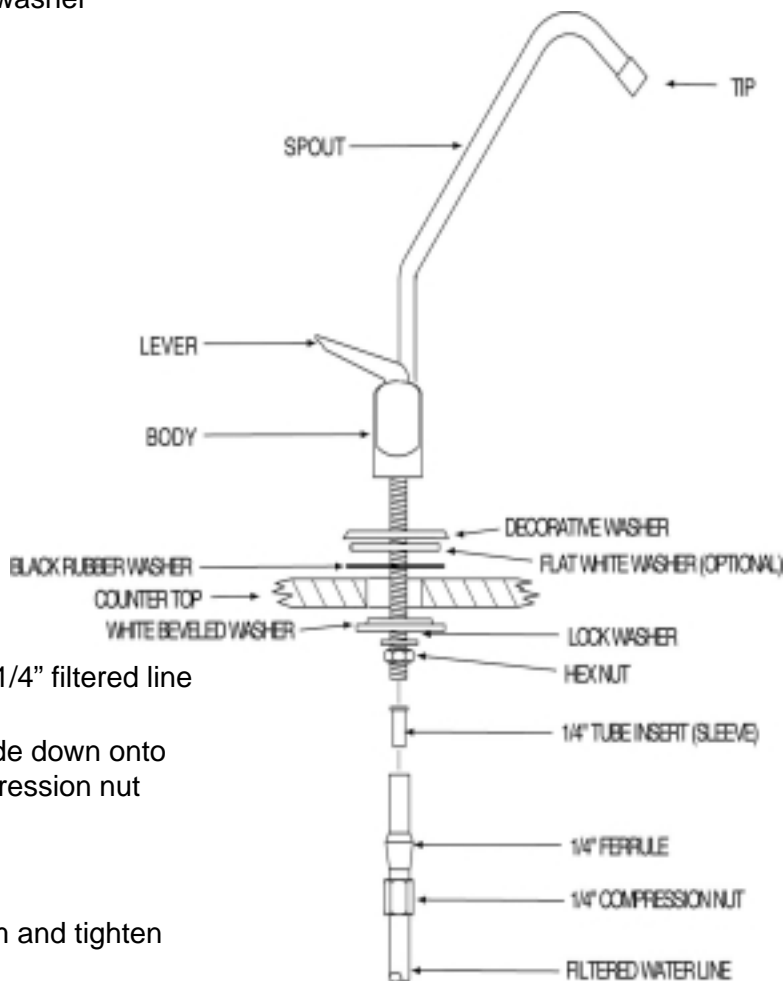

CAUTION: Do not overtighten fittings

Note: Spout pulls out from faucet body that's why it swivels. Spout has 2 o-rings at base and is inserted completely into bottom of body to prevent leaking. Handle and tip can also be removed.

**Other faucets check specifications, all dimensions are approximate.

Dispenser/Faucet (no Air Gap) Installation is now Complete. Go To Inlet Water Connection



Inlet Water Connection

Professional Installation is Strongly Recommended

This unit is supplied with a saddle tapping valve and is a proper connection for 1/2" hard copper lines only. A qualified plumber may/will choose to use another adapter to connect the feed water supply.**

Instructions if using the supplied saddle tapping valve

Step 1: Inside the parts box locate: saddle tapping valve and 4' of 1/4" tubing, color coded: red or orange

Step 2: Locate cold water line that feeds your existing faucet. Determine if there is enough space to install the saddle tapping valve on the 1/2" copper line between the wall and the angle stop.

CAUTION: USE ONLY COLD WATER LINE. NOT INTENDED FOR SUPPLY BY HOT WATER.

Step 3: Shut off the main water supply to the house and open the faucet to relieve water pressure in the 1/2" copper pipe. NOTE: Shutting the angle stop only, still leaves water in that pipe. Shut the main supply.

Step 4: Loosely assemble saddle tapping valve around 1/2" copper pipe with "V" notch of the bottom bracket towards pipe.

CAUTION: Do not turn valve handle before instructed to do so. Make sure the piercing lance does not protrude beyond the rubber gasket.

Step 5: Tighten screws evenly. Make sure brackets are parallel, then tighten firmly until the valve is not moving on the pipe.

CAUTION: Do not over tighten.

Step 6: Connect the 1/4" plastic tubing to the saddle tapping valve by following these instructions:

A: Place 1/4" brass insert sleeve into the end of the 1/4" plastic tubing

B: Slide 1/4" compression nut over plastic tubing with threads toward the saddle tapping valve

C: Slide 1/4" plastic ferrule over plastic tubing with long tapered side towards compression nut

D: Insert tubing into saddle tapping valve

E: Tighten compression nut onto saddle tapping valve.

CAUTION: Do not over tighten.

F: Be sure the handle packing nut is tight, then turn the handle of the saddle tapping valve clockwise until it is firmly seated. **NOTE:** The 1/2" hard copper pipe is now pierced.

G: Turn the handle counter-clockwise to open the valve for water supply.

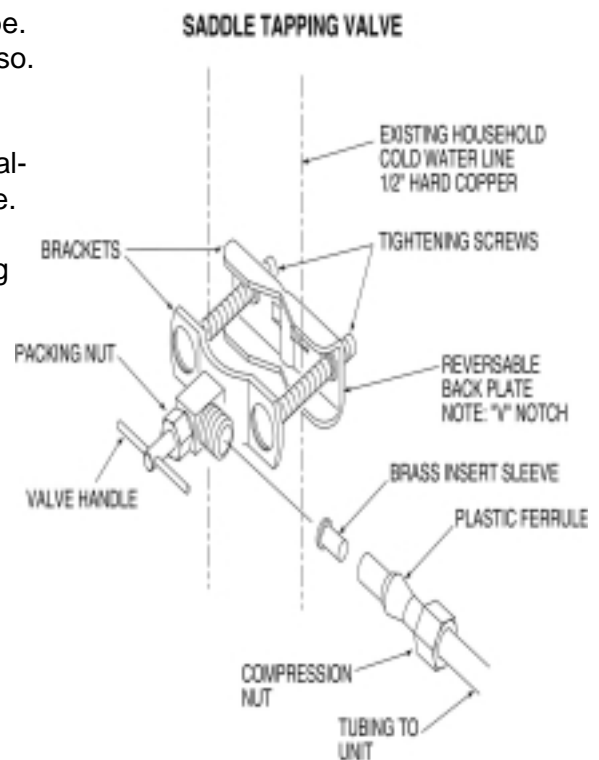

**EWS, Inc. can not anticipate all the different locations, applications and materials used by your builder and/or plumbing contractor regarding your household or sink piping, therefore we offer a generic and common fitting with proper instructions. A qualified plumber, plumbing supply location, or hardware store will have no problem with alternative parts and advice necessary to install your unit.

Water Supply/Connection Options:

There are a number of options to properly install any one of our water filtration systems. Identify the cold water supply line, the size/diameter and the material it's made from, along with any fittings you observe at the ends of the supply line.

Examples of connections available at your local hardware store

• BEST OPTIONS: 1/2" IPS x 3/8" compression x 1/4" compression 3-way angle stop

• BEST OPTIONS: 1/2" compression x 3/8" compression x 1/4" compression 3-way angle stop

• BEST OPTIONS: angle stop 2-way adaptor: install on the angle stop outlet which becomes a 2-way angle stop

Note: Be sure one outlet is 1/4" compression for water filter 1/4" inlet/supply tubing

Proper installation is dependent on your specific application. However, the idea is universal. Locate the supply pipe, shut off your water, install the proper connections and follow the remaining instructions in this manual

Inlet Water Connection is now Complete. Go To the Placement of the System



Placement of the Water System and Storage Tank

Simply place the water system on a level floor, cabinet bottom or horizontal surface. Always assume for enough space for the system and storage tank, and tubing to remove, move and/or adjust for filter and membrane replacement and maintenance.

If mounting the system to a wall, cabinet side or other vertical surface, see the following;

Step 1: All filter cartridges and membranes for the system are preinstalled. If the unit is installed in a permanent hanging position, a minimum clearance of 2" will be required to allow filter replacement.

Step 2: Mark pilot holes using the bracket as a template.

Step 3: Using a drill bit or punch, drill a hole or punch as a starter hole to catch the mounting screws.

WARNING: ALTERNATIVE FASTENING METHOD MAY BE REQUIRED FOR PLASTER BOARD, PARTICLE BOARD OR SIMILAR MATERIAL INSTALLATION. USE SAFETY GLASSES OR OTHER EYE PROTECTION TO PREVENT POSSIBLE EYE INJURY DUE TO FLYING PARTICLES.

Step 4: Set mounting screws (provided) with screw driver. Leave a 1/4" gap between the screw head and mounting surface to allow the bracket to slide on easily.

Step 5: Slide the bracket over the screws and hang the unit.

WARNING: UNLIKE SIMPLER, PASS-THROUGH, DRINKING WATER SYSTEMS, REVERSE OSMOSIS HAS A STORAGE BOTTLE, DRAIN CONNECTIONS AND AN RSR VALVE. UPON INSTALLATION THE SYSTEM MAY HAVE TO BE "BURPED" OF ANY AIR POCKETS BY ROTATING AND HOLDING UNIT 90° DEGREES TO THE LEFT AND THEN 90° TO THE RIGHT TO ELIMINATE AIR IN THE SYSTEM.

Open the box containing the storage tank and plastic base. Place storage tank on the plastic base near the system and allow for room for connections.

Tank shut off valve with quick connect

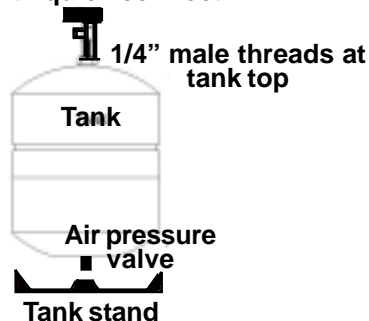

Storage Tank:

The storage tank holds 3.2 gallons of product water at 40 psi. A diaphragm inside the tank keeps water under pressure. The tank has an air pre-charge of 5-7 psi from the factory.

Storage Tank Preparation:

Locate: plastic tank stand and tank shut off valve

Note: 1/4" male threads at top of tank and air pressure valve at bottom of tank

Step 6: Note: air pressure valve seats into tank stand when tank is in upright position. Place tank on stand. Note: Tank may be placed on its side, if necessary.

Step 7: Using Teflon tape (not included) wrap 1/4" male threads on storage tank using clockwise motion for at least two revolutions. There is no need to overtighten

Step 8: Install tank shut-off valve on storage tank. Do this by hand tightening valve clockwise onto male threads of the storage tank.

Step 9: Set aside until needed and proceed to Drain Connector Installation.

Open Valve - In line with tubing and connection. **Closed Valve** - 90° angle to tubing and connection



Drain Installation and Connection

Step 1: From the parts bag locate: Drain saddle assembly, 1/4" quick connect fitting (for use with non-air gap installation), 3/8" quick connect fitting (for use with air gap installation).

Step 2: Placement of drain saddle should be located on the vertical tail piece of your plumbing system at least 2" above the horizontal outlet or trap assembly.

NOTE: Placement above 2" can increase the chance of noise in your waste line
Drain connection should be pointing out or towards you as you are looking out over the cabinet.
An alternate location for the drain saddle is on the horizontal drain pipe as pictured below.

Step 3: Using a 1/4" drill bit, drill a hole slightly above the drain saddle.

WARNING: IF DRILLING METAL PIPE, PROTECT YOURSELF FROM SERIOUS INJURY OR FATAL SHOCK, USE A HAND DRILL OR A CORDLESS DRILL TO MAKE THE HOLE. IF YOU USE AN ELECTRIC DRILL, OUTLET MUST BE GROUNDED. USE SAFETY GLASSES OR OTHER EYE PROTECTION WHEN GRINDING TO PREVENT POSSIBLE EYE INJURY DUE TO FLYING PARTICLES.

Step 4: Loosen drain saddle and slide over the 1/4" hole. Tighten drain saddle using a screwdriver, while aligning the hole in the drain pipe to the hole in the drain saddle.

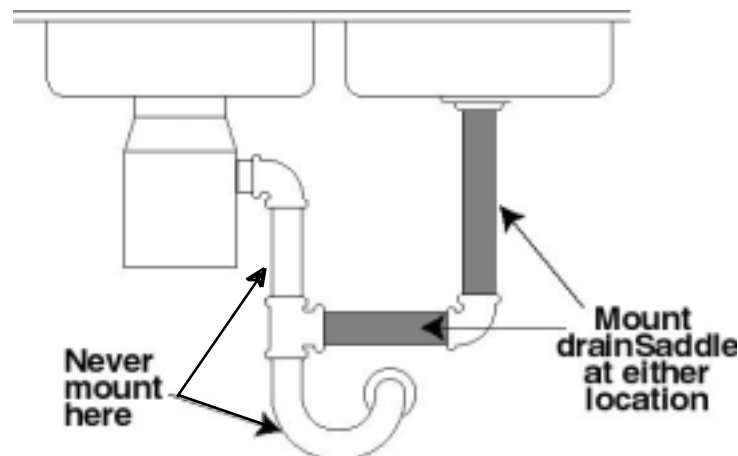

WARNING: When installing drain saddle on a horizontal pipe - always install connection at the 10 o'clock or 2 o'clock position (as illustrated to either the left or right) to allow for proper flow of RO rejection water and to prevent cross-contamination

Interconnection to Supply, Drain, Storage Tank and to Faucet/Dispenser (with or without air gap)

Always
Cut Tubing
Straight

Do Not
Flatten

Insert Firmly
and
Completely

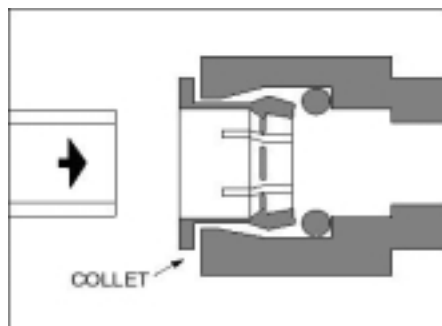

SIMPLY PUSH IN TUBE TO ATTACH

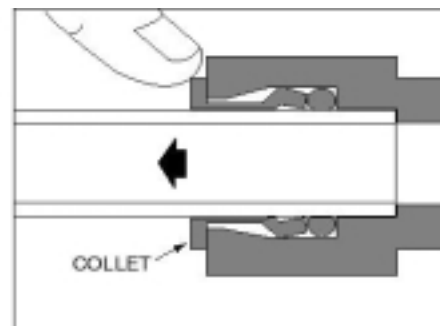

PUSH IN COLLET TO RELEASE TUBE

Never
Pull Tube
Out To
Remove

Push Collet
In To
Release



Before Making the Connections

- NOTE:** This system may have come with sample tubing. Please remove before installation.
- WARNING:** DO NOT PULL OUT TO REMOVE. Follow simple instructions to remove.
- INSPECT:** Inspect the fitting for any damage from shipping and/or handling. **STOP**, if collet is damaged in any way and call/e-mail customer service for a replacement fitting.

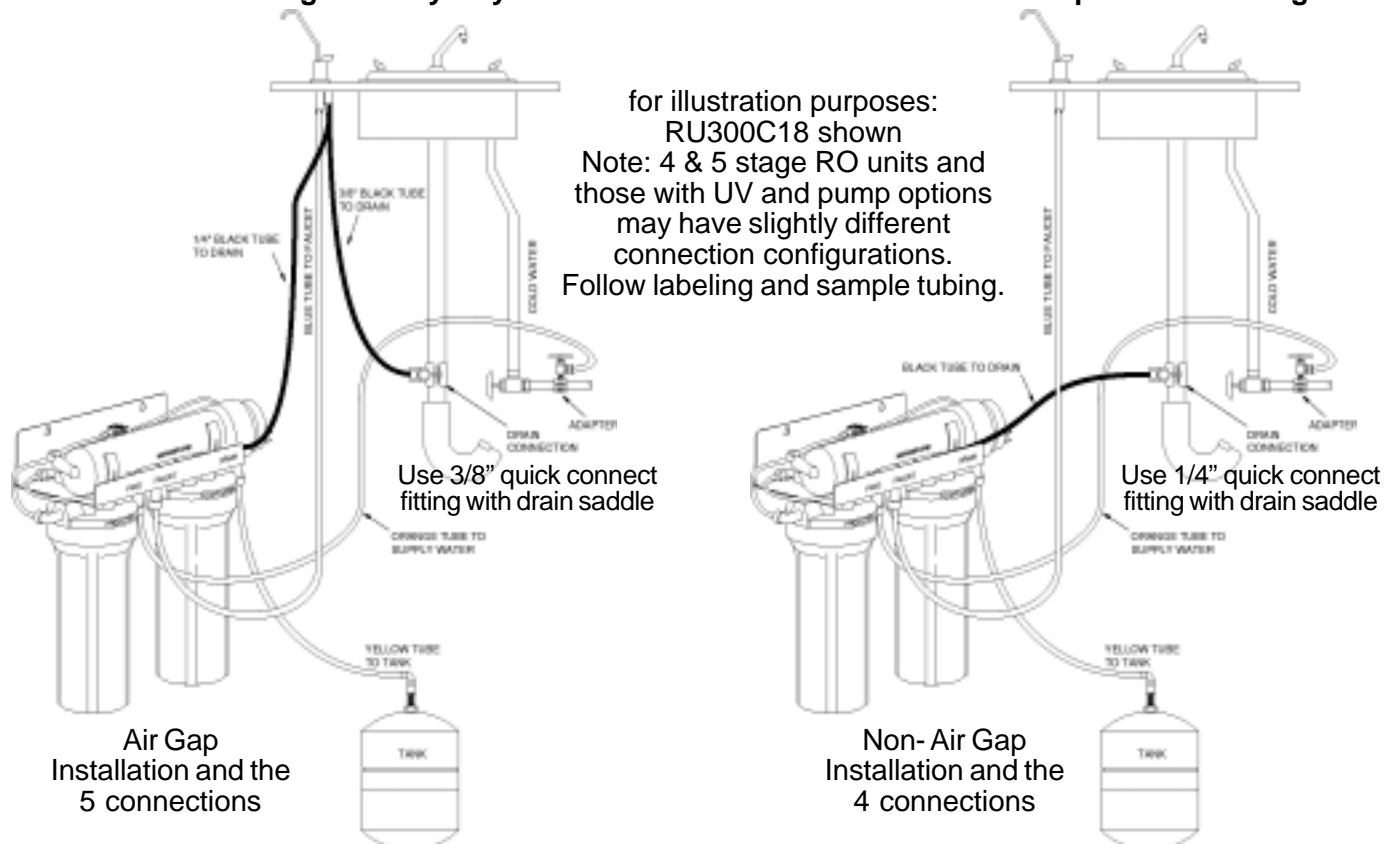

System Interconnections. Please follow labeling or sample tubes for proper connections

- Step 1: From Water Supply to RO Unit:** Connect the orange tube from the location on the RO unit marked "Prefilter," "Feed" or "In" and then connect to the water supply. Press and insert the tubing into the fittings.
- Step 2: From RO Unit to Faucet:** Connect the blue tube from the location on the RO unit marked "Faucet" or by the "Postfilter" or identify the connection with the blue sample tube and then connect to the faucet. Press and insert the tubing into the fittings.
- Step 3: Tank Connection:** Connect the yellow tube from the location on the RO unit marked "Tank" or identify the connection with the yellow sample tube and then connect to the tank. Press and insert the tubing into the fittings.
- Step 4: Drain Connection:**
- Air Gap: Connect the black 1/4" tube from the location on the RO unit marked "Drain" and connect to the 1/4" barbed connection on the air gap. Then, connect the black 3/8" tube from the 3/8" barbed connection on the air gap to the drain saddle assembly.
- Non Air Gap: Connect black 1/4" tube from location on the RO unit marked "Drain" to the drain saddle assembly

- NOTE:** If excess tubing exists, it may be cut to length.
- WARNING:** Do not allow tubing to loop. Do not allow tubing to kink. See illustrations above.

Making the Connections

- NOTE:** You may feel a resistance at the o-rings when you insert the tubing. Firmly insert the tubing completely into the fitting.
- CAUTION:** ALWAYS CUT TUBING STRAIGHT (NO ANGLE OR SLANT) TO FORM A STRAIGHT END.
- WARNING:** NEVER ATTEMPT TO REMOVE TUBING BY JUST PULLING. Follow easy instructions.
- INSPECT:** Upon installation, inspect the connection and give the tubing a gentle "tug" to insure proper connection and integrity of the fitting.



System Start-Up and Operation

Step 1: (if applicable)

A) Connect available UV lamp cords and plug in transformer unit to typical 110v electric outlet.

B) Connect available Booster Pump cords and plug in transformer unit to typical 110v electric outlet.

NOTE: Electrical outlet must be unswitched. Be aware of any GFI outlets and the need to reset. Surge suppression recommended.

Step 2: Storage tank valve should be closed, so that handle is perpendicular to the line exiting the tank.

Step 3: Pull up and lock dispenser/faucet handle in the open position

Step 4: Turn on any main water supply which was shut off earlier.

Step 5: Open or make sure there is inlet water supply to the system

Step 6: Water will begin to flow from dispenser/faucet. This will rinse away membrane preservatives.***

Step 7: Open storage tank valve by turning tank valve handle so it is parallel to the line exiting the tank.

Step 8: Allow system to fill the tank twice and drain both tanks of water produced before actual use. This will wash carbon fines, preservatives, and air from the system. This process may take 8-15 hours.***

Step 9: Allow system to fill and use as normal.

NOTE: If you draw your water into a glass and it appears to be cloudy, it's only air and nothing bad. Let the glass sit and watch the air rise and dissipate. The filter cartridges used are full bed depth. The carbon (GAC) cartridges have great deal of surface area. It may take 24-48 hours for this to correct it self.

Step 10:

Inspect for leaks at all connections. If a problem exists, please shut off water supply to the system and consider the following solutions;

- Plumbing connections at dispenser/faucet and inlet supply. Please review these procedures.
- Inspect for leaks at all system connections such as connections between housings, the membrane and cartridge housings and all the tubing connections. Give a light "tug" (not a hard pull) on all tubing to check the grip on all fittings.

If there any problems, please call or e-mail.

- Please identify any damage in shipping or handling. You'll need to make a claim with the shipper, as indicated on your packing materials, the packing slip and the published terms of sale.
- Please identify any problem and let us know if we can offer advice or a part that we can readily send you.

NOTE: Reverse Osmosis systems have specific issues with air in system, proper pressure in tank, the proper draining of reject water, proper connection between various components, etc. and one should be familiar with the trouble shooting guide in this manual.

*****CAUTION:** Do not drink water from system until start-up procedures have been completed and system has been flushed properly. Improper start-up result in poor performance of the system

WARNING: Maximum pressure is 75 PSI. Pressure unregulated can surge or exceed the maximum rating on this and many items in the home. High pressure creates a water hammer or banging pipes. It's also the reason we use stainless hoses for washer machine connections and not the rubber. A pressure reducing valve (PRV) at your main water service line (if not code) is greatly recommended by many manufacturers' of many different household items, plumbing products and appliances.

PLEASE:

- Familiarize yourself with the system, its replacement filters and maintenance.
- Understand your system's capabilities
- See your options in water treatment, for you , your family and your home by EWS, Inc.

REGISTER:

- Register your system with our confidential data base and be reminded to replace your filters



Replacement of Filter Cartridges

It is recommended that filters be changed at least annually or more frequently based on usage and local water conditions. Pre-filters before the membrane must be carefully monitored. The quantity and quality of the water processed effects the life of the filters.



Step 1: Close inlet water supply to the system.

Step 2: Close storage tank by turning clockwise (should be perpendicular with the line exiting the tank).

Step 3: Open dispenser/faucet. Lock handle in the up position and allow water to flow. Allow water to drip for 15-30 minutes, then close dispenser/faucet.

CAUTION: WATER WILL BE PRESENT WHEN FILTERS ARE CHANGED.
A pan, towel, etc. should be placed under the housings to catch any water.

Step 4: Using your spanner wrench, turn housing base counterclockwise to loosen. Remove base.

Step 5: Remove filter from base and dispose.

NOTE: See disinfection procedure before replacing any filters, membranes or UV lamp (if applicable)

Step 6: Insert new filter(s), replace and tighten housing base by turning clockwise.

CAUTION: The GAC filters have gaskets that must be at the top of the filter to be replaced correctly. All other filters do not have a top or bottom (or have gaskets) and can be inserted either way.

CAUTION: Inspect O-Ring for housing base. Make sure it is clean, free of any deris and not damaged or kinked. Make sure it is correctly seated into the channel inside the housing before replacement.

Step 7: FOLLOW SYSTEM START-UP PROCEDURES FROM PAGE 4.2-10

Replacement of the Membrane

It is recommended that membranes, if possible be tested annually and changed as needed, approximately, up to, every 2-3 years. Consider 18 months (1 1/2 years) to be a realistic and conservative standard or more frequently based on usage and local water conditions. Pre-filters before the membrane must be carefully monitored and replaced to protect membrane. The quantity and quality of the water processed affects the life of the filters.

Step 1: Close inlet water supply to the system.

Step 2: Close storage tank valve by turning clockwise (should be perpendicular with the line exiting the tank).

Step 3: Open dispenser/faucet. Lock handle in the up position and allow water to flow. Allow water to drip for 15-30 minutes, then close dispenser/faucet.

CAUTION: WATER WILL BE PRESENT WHEN FILTERS ARE CHANGED.
A pan, towel, etc. should be placed under the housings to catch any water.

Step 4: Use the Quick Connect diagram to disconnect the water feed tube from the top of the membrane vessel.

Step 5: Unscrew the top of the membrane vessel counterclockwise and remove the old membrane.

Membranes come standard with a nipple and o-ring which inserts and seats into the back of the membrane housing. However, membranes come in two styles to allow the extraction of the membrane from the housing. Either an extension (use needle nose pliers) or a threaded insert (using a screw, thread into insert and then pull screw to remove).

Step 6: Place a light coat of food-grade silicone grease or petroleum jelly on the O-Ring and black seal before replacement.

Step 7: Insert the new membrane with o-ring end in and allow to seat. Screw cap back on.

Step 8: Re-insert feed water tube into the top of the membrane vessel (see Quick Connect diagram).

Step 9: Open inlet water supply. Open storage tank valve (should be parallel with the line exiting the tank).

Step 10: FOLLOW SYSTEM START-UP PROCEDURES FROM PAGE 4.2-10

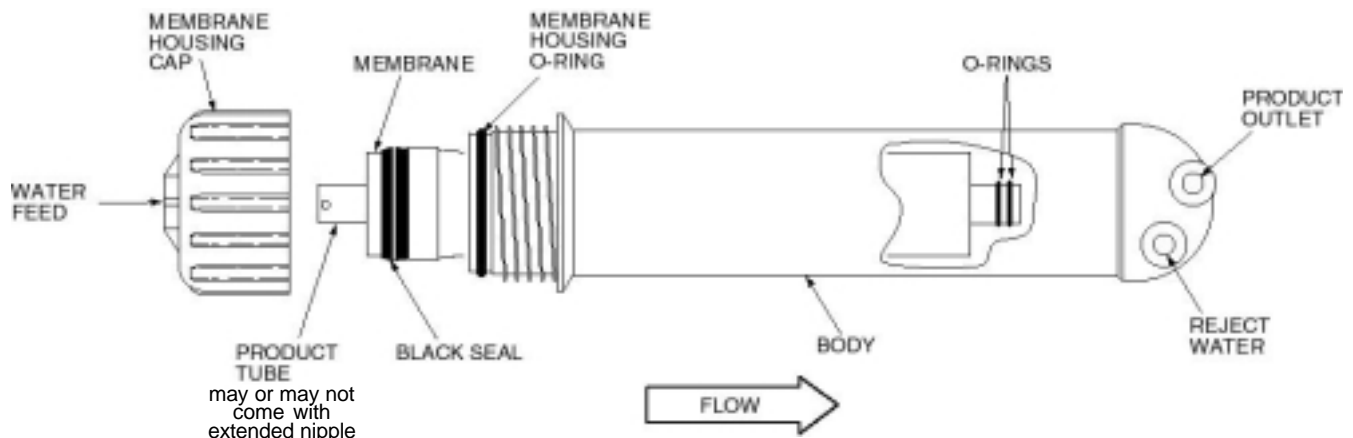



Replacing the Ultra Violet Lamp (if applicable)

Step 1: Unplug the transformer. Disconnect the UV lamp cord.

Step 2: Pull firmly on the UV lamp tail to remove the lamp.

Step 3: Insert and firmly press in new UV lamp until it meets the top of the cap. Reconnect UV lamp cord.

Step 4: Plug in unit transformer

WARNING: DO NOT DISCONNECT UV MODULE FROM THE FACTORY CONNECTIONS AND DO NOT OPEN UV CAP FROM UV MODULE FOR TYPICAL UV LAMP REPLACEMENT

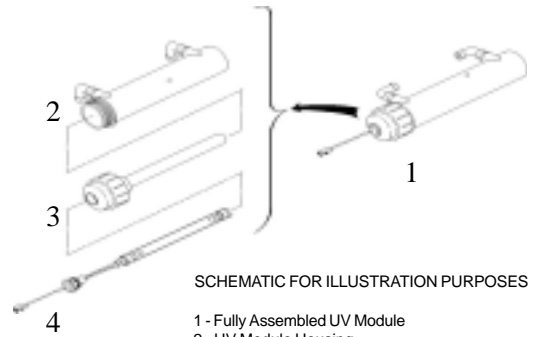

SCHEMATIC FOR ILLUSTRATION PURPOSES

- 1 - Fully Assembled UV Module
- 2 - UV Module Housing
- 3 - UV Cap with Quartz Glass Sleeve
- 4 - UV Lamp with Lamp Cord

When disconnecting and/or connecting tubing to the Quick Connect Fittings on the inlet (in/feed) and outlet (out/filtered):

CAUTION:
FOLLOW SYSTEM INTERCONNECTION INSTRUCTIONS ON PAGE 4.2-8

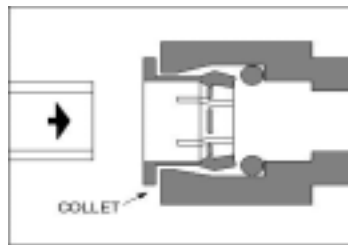

SIMPLY PUSH IN TUBE TO ATTACH

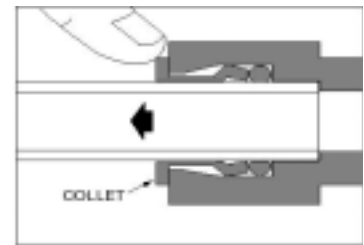

PUSH IN COLLET TO RELEASE TUBE

Disinfection Procedure

This procedure may be performed at any time when changing filters, membranes and/or UV lamps or after extended periods of inactivity of the system.

- Step 1:** Follow Steps for Replacement of Filter Cartridges, Membranes, and UV Lamps. Empty all housings.
 - Step 2:** Using chlorine bleach, measure 1/2 cup and pour into first housing base (nearest the "Inlet"/"In"/"Feed").
 - Step 3:** Replace all empty housings and secure. Take note of any housing O-Rings. Keep dispenser/faucet closed
 - Step 4:** Slowly Open water inlet valve and allow system to completely fill. Open tank valve (handle is parallel to line exiting tank) Let water sit in system for at least 5 minutes (leaving it for a longer time will not hurt). Always dispose of the first tank of water after performing this procedure.
 - Step 5:** Open dispenser/faucet and let the water run for at least 5 minutes. **WARNING: DO NOT USE THIS WATER.**
 - Step 6:** Now that the system has been disinfected. Re-open the housings as in previous procedures and wipe away any residual found to totally clean this system prior to new filters, membranes, and/or UV lamp replacement.
- FOLLOW STEPS FOR: Replacement of Filter Cartridges, Membranes and UV Lamp (if applicable)
 - FOLLOW STEPS FOR: System Start-Up and Operation

RSR-100 (CTA Membranes) and RSR-150 (TFC Membranes) Control Valves

Installed on every R.O. Unit produced by EWS, Inc.

- 1) The control valve monitors the water entering the storage tank and when the storage tank is full, the valve turns off the water processing of the system. Less Waste.
- 2) The control valve regulates the correct amount of reject water flushed to the membrane.
- 3) The control valve has a positive sealing check valve. The check valve accurately monitors internal pressure and protects the system from pressure surges and reverse flows which could damage the membrane.

Note: It is important to completely empty the storage tank monthly to provide a complete tank of fresh water to prevent TDS "creep" which prevents the proper pressure on this control valve.

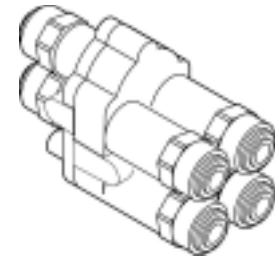

Correct Application of Booster Pumps

Booster pumps are critical to the effective performance of reverse osmosis membranes and are recommended in applications where feedwater pressure is less than 40 PSI. Feedwater high in Total Dissolved Solids (TDS) may need a boost, in order to perform within rejection parameters.

Standard Components: Always connect in the following order:

- 1) Transformer 2) TSO 3) Pump

Tank Shut-Off Switch -TSO: Mounted in-line with the hydro-pneumatic pump as close to the tank as possible. The purpose is to turn the booster pump off when the tank is full.

Please consult EWS, Inc. for proper applications and specifications.



Pump comes fully assembled as option with RU500T35 units



Trouble Shooting Guide - Reverse Osmosis Systems

Problem	Possible Causes	Solution
No water	Water supply is off	<ul style="list-style-type: none"> •Turn main water supply on •Turn water on at inlet connection •Open dispenser/faucet
Not enough water	Low water pressure	Unit may not operate properly at less than 25 PSI feed line pressure (max: 75 PSI)
Leak at inlet or outlet fittings	<ul style="list-style-type: none"> •Is the tubing cut with a straight end to grab squarley? •Is the tubing inserted completely into fitting? •Is there a problem with the collet and the quick-connect fitting? 	<ul style="list-style-type: none"> •Access the filter unit, remove tubing by depressing the collet and pulling tubing out. Using a utility razor knife, <u>squarely</u> cut 1/2" off tubing from the end. Make sure end of tubing is not flattened Reinsert the tubing into the fitting as far as possible. Check for leaks. •Tug on tubing (do not pull hard) to check fitting
Leak at connections to, or between housings	Damage in shipping/handling	Call for part replacement
Leak at faucet or supply or other connections	Varied Causes	Check connections at various locations. Remove, cut straight and re-insert tubing or connections. Tighten or correct or request part
Leak at cartridge housing	Misaligned, damaged or missing O-Ring(s)	<ul style="list-style-type: none"> •Locate and Align O-Ring into groove inside housing •Call for replacement part
Any/all leaks	Excessive Pressure	Pressure reducing valve (PRV) at main water supply to maintain pressure at or below 75 PSI
Water Flow is Restricted	Kinked or Bent Tubing	Make longer loop with tubing to remove kink or bend
UV not working	Lamp damaged, lamp cord has not been connected or transformer is not plugged in.	<ul style="list-style-type: none"> •Connect lamp cord and/or Plug in transformer. •Make sure unit plugged into an unswitched electrical outlet. Check GFI reset. •Surge suppression recommended •Replace UV Lamp,
Unpleasant taste and/or odor Metallic flavor Discoloration Rotten egg smell from water	<ul style="list-style-type: none"> •Need to replace filters, membrane •System needs disinfecting •System was idle, stored or misused for a long period of time. •System under unfavorable conditions or changing water conditions •Hydrogen sulfide, iron, manganese is in the household water supply •System misapplied 	<ul style="list-style-type: none"> •Replace filters and follow start up procedures •Replace and disinfect: See page 12 for instructions •Flush system by running water, replace filters, membrane, and/or disinfect •Determine what changed in your water supply and Flush, Replace and/or Disinfect, or change type of water treatment system based on local water conditions. Call your municipality or have your well tested. •Hydrogen sulfide, iron and manganese must be removed from household water supply before filter system. Visit our web site and see the Pyrolox systems •The wrong system for the application
Low flow from unit	Clogged prefilter cartridge	Replace sediment and/or other filters
Cloudy water	<ul style="list-style-type: none"> •New installation, changing filters, disinfecting the system •Open/close and open of water supply to home or in home 	It is simply - air. Check by filling glass and watch air dissipate. Run and flush system for several minutes. Sometimes it takes 24 - 48 hours to totally clear due to the full bed depth of our filters



Trouble Shooting Guide - Reverse Osmosis Systems - continued

Problem	Possible Causes	Solution
Salty taste or "whitish" ice cubes. TDS test indicates less than 75% rejection.	RO membrane fouled or expended.	Replace all filter cartridges and membrane and disinfect the system.
Tank fills much faster than usual (less than 30 minutes)	RO membrane fouled or expended.	Replace all filter cartridges and membrane and disinfect the system.
RO unit will not flush at full force	Clogged prefilter cartridge(s) Water supply is turned off Low water pressure or High TDS	Replace sediment and carbon prefilter Turn water on Unit will not operate at less than 35 psi feed line pressure
Not enough water	Storage tank depleted due to usage Clogged pre-filter restricting flow	Consider adding additional tank to your system if this occurs frequently Replace prefilter
No or slow drain water Leaking drain assembly and or water coming out of air gap Leak or water coming from air gap opening in faucet.	Clogged brine restricter Misalignment of hole in drain saddle or no hole drilled. Vibration from disposal Waste line tube to long, looped or kinked creating a trap or backup	Replace brine restricter, maintain filters Realign drain saddle, make sure hole is drilled and clear of debris. Tighten bolts, vibration shifts drain saddle and needs to be aligned Cut drain tube to length and prevent any looping of tubing or kinking
Excessive noise coming from faucet.	Hole or drain tube is blocked with debris Excessive slack in drain tubing	Remove debris Cut off excess drain tubing See: all drain issues above
Not enough product water pressure	Low air tank charge TDS "creep"	Empty water from storage tank and adjust air pressure in tank up to 8 psi. Storage tank needs to drained completely and filled fresh monthly
Excessive water to drain	TDS "creep", not enough pressure against RSR valve to shut off reject water	Storage tank needs to drained completely and filled fresh monthly to prevent older, higher TDS water at bottom of tank (similar to pools)

NOTES:

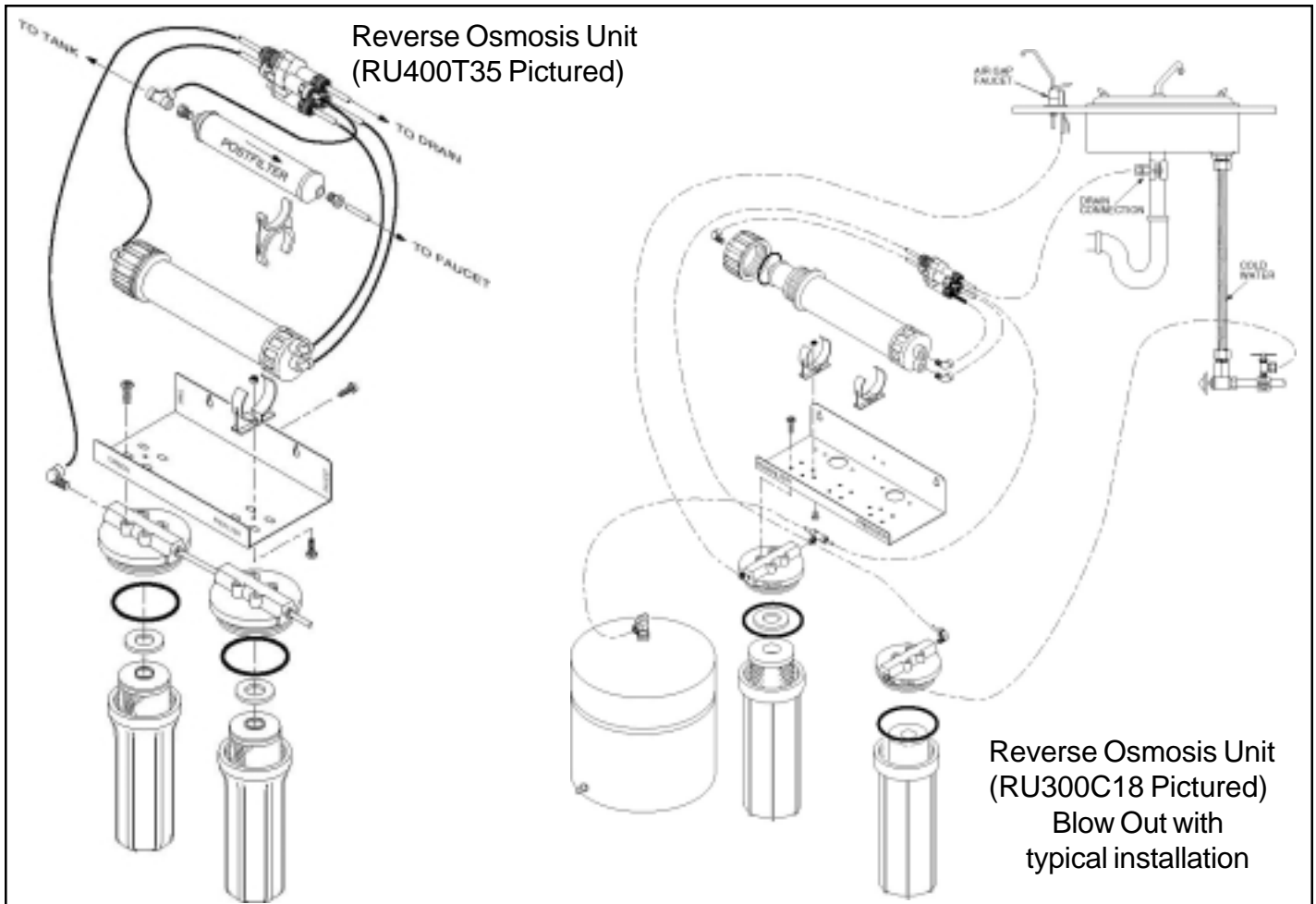

Reverse Osmosis Unit
(RU300C18 Pictured)
Blow Out with
typical installation

Ref. No.	Part No.	Description of Parts for RU400T35
1	020-MVH	M/H; STRAIGHT PORT
2	141S152	RO102W 3.2 GALLON TANK
3	158125	#10 SL WHITE/WHITE WO/PR
4	93023	PX05-9 7/8" 5M SED CARTRIDGE
5	CI010821W	JG 1/4" X 1/8" M COMM - White on RSR
6	PIO10821S	JG 1/4" X 1/8" CONN - Grey on RSR
7	CI100822S	JG 1/4" SWIVEL BRANCH T
8	CI480821W	JG 1/4" X 1/8" FIXED ELBOW; WHITE
9	CI480822W	JG 1/4" X 1/4" FIXED ELBOW; WHITE
10	HS-03A-W	.090 ALUM BRACKET; POWDER COAT
11	PDC602F	DRAIN CONNECTOR; 1/4" FPT
12	PI480821S	JG 1/4" X 1/8" FIXED ELB
13	PPC202W	WHITE 2" FAST CLIP
14	T112N-35D	35 GPD DRY MEMBRANE
15	PPSV-500822W	1/4" FQC X 1/4" FPT EL-VALVE
16	QMP-102W	LONG REACH FAUCET; WH/WH
17	QMP-500-3	AIR GAP FAUCET ADAPTER
18	RSR100-150	150 GPD RSR FLOW RESTRICTOR
19	STV-2	SELF PIERCING SADDLE VALVE
20	TUB4BKP60	1/4" PE TUBING; 60"; BK-P
21	TUB4BLP60	1/4" PE TUBING; 60"; BL-P
22	TUB4ORP60	1/4" PE TUBING; 60"; OR-P
23	TUB4YLP60	1/4" PE TUBING; 60"; YL-P
24	UDF10HP	10" GAC CARTRIDGE
25	PI010822S	1/4" X 1/4" MALE CONNECTOR
26	PI011222S	3/8" X 1/4" MALE CONECTOR-Air Gap Kit
27	TUB6BKP	3/8" PE TUBING BLACK - Air Gap Kit
28	FH4000	HOUSING O-RING
29	020-MVH-0	O-RING KIT (Not Shown)
30	CL10ROT40-B	10" T40 CARBON INLINE; 1/4" FNPT
31	PPC212W	DOUBLE CLIP - WHITE

Ref. No.	Part No.	Description of Parts for RU300C18
1	020-MVH	M/H; STRAIGHT PORT
2	141S152	RO102W 3.2 GALLON TANK
3	158125	#10 SL WHITE/WHITE WO/PR
4	93023	PX05-9 7/8" 5M SED CARTRIDGE
5	CI010821W	JG 1/4" X 1/8" M COMM - White on RSR
6	PIO10821S	JG 1/4" X 1/8" CONN - Grey on RSR
7	CI100822S	JG 1/4" SWIVEL BRANCH T
8	CI480821W	JG 1/4" X 1/8" FIXED ELBOW; WHITE
9	CI480822W	JG 1/4" X 1/4" FIXED ELBOW; WHITE
10	HS-03A-W	.090 ALUM BRACKET; POWDER COAT
11	PDC602F	DRAIN CONNECTOR; 1/4" FPT
12	PI480821S	JG 1/4" X 1/8" FIXED ELB
13	PPC202W	WHITE 2" FAST CLIP
14	CTA-18	18 GPD CTA MEMBRANE
15	PPSV-500822W	1/4" FQC X 1/4" FPT EL-VALVE
16	QMP-102W	LONG REACH FAUCET; WH/WH
17	QMP-500-3	AIR GAP FAUCET ADAPTER
18	RSR100-90	90 GPD RSR FLOW CONTROL
19	STV-2	SELF PIERCING SADDLE VALVE
20	TUB4BKP60	1/4" PE TUBING; 60"; BK-P
21	TUB4BLP60	1/4" PE TUBING; 60"; BL-P
22	TUB4ORP60	1/4" PE TUBING; 60"; OR-P
23	TUB4YLP60	1/4" PE TUBING; 60"; YL-P
24	UDF10HP	10" GAC CARTRIDGE
25	PI010822S	1/4" X 1/4" MALE CONNECTOR
26	PI011222S	3/8" X 1/4" MALE CONECTOR-Air Gap Kit
27	TUB6BKP	3/8" PE TUBING BLACK - Air Gap Kit
28	FH4000	HOUSING O-RING
29	020-MVH-0	O-RING KIT



The complete EWS, Inc./Environmental Water System product line from sink to whole-home, available through:

Available on the Internet through Authorized Retail Web Distributors and Business-to-Business E-Commerce Distributors.

Available through Authorized Building Wholesale Supply Locations, Kitchen & Bath Showrooms and Appliance Dealers, and their Building and Plumbing Contractors throughout the United States.



EWS, INC.
Environmental Water Systems
A Complete Line of Water Filtration Product from Sink to Whole-Home

9101 W. Sahara Avenue #105-J8
Las Vegas, Nevada 89117

Telephone: 702-256-8182 Fax: 702-256-3744
E-Mail: customerservice@ewswater.com
Visit us on the web at: www.EWSWATER.com

This service guide and all materials herein is the property and copyright of EWS, Inc. 05/03: 051803



Providing information to help consumers.
All Product Proudly Manufactured and Assembled in the USA

www.EWSWATER.com